



# SP48

SPEAKER PROCESSOR

**USER MANUAL**

# CONTENTS

INTRODUCTION .....	4
FEATURES .....	4
GETTING STARTED .....	5
CONNECTING THE SP48.....	6
Passive TNA System.....	6
Passive TNi-C6 System .....	7
Active TNA System.....	8
Mixed TNA System.....	9
SP48 PROCESSOR OVERVIEW.....	10
REAR PANEL .....	10
FRONT PANEL.....	11
Encoders, Enter and ESC buttons.....	12
FACTORY RESET .....	13
UTILITIES .....	14
SYSTEM UTILITIES.....	15
Delay Units.....	15
Set Default Value.....	15
Firmware Version .....	15
PROGRAM UTILITIES .....	15
Recall a Program .....	15
Save a Program .....	15
Delete a Program.....	15
INTERFACE UTILITIES.....	16
Interface Setup .....	16
SECURITY UTILITIES.....	17
Show Parameter .....	17
Lock Unit .....	17
Change Password .....	17
Lock With Password.....	17
EDITING .....	18
INPUTS A/B/C/D .....	19
Name .....	19
Noise Gate .....	19
Gain .....	20
Delay.....	20
Polarity.....	20
RMS Compressor .....	21
EQ Bypass .....	22
30 Band EQ [EQ-01 -> EQ-30].....	22
OUTPUTS 1~8 .....	24
Name .....	24
Routing Page .....	24
Gain .....	24
Delay.....	24
Polarity.....	25
LIMITER.....	25

HPF.....	26
LPF .....	26
EQ Bypass.....	27
7 Band EQ [EQ-01-> EQ-07].....	27
LINKING INPUTS AND OUTPUTS.....	28
USING THE CONTROL APP .....	29
Installation.....	29
Connecting to Device.....	31
USB .....	31
RS485.....	32
Multiple connections .....	33
DEMO MODE .....	35
Rout Screen.....	35
Level Screen .....	37
Input Screen.....	38
Output Screen .....	39
Editing channel names .....	40
View All Graph.....	40
MENU .....	41
LOAD.....	41
SAVE .....	41
STORE.....	41
RECALL.....	42
COPY IN .....	42
COPY OUT .....	42
DEFAULT.....	43
USER .....	43
LOCK .....	43
PASSWORD .....	43
ABOUT .....	44
TECHNICAL SPECIFICATIONS.....	45
DIMENSIONAL DATA (in mm).....	46
SAFETY INFORMATION.....	47

## INTRODUCTION

The HH Electronics SP48 is a fully featured 4-IN/8-OUT digital speaker management system. Featuring 4 analogue inputs and 8 analogue outputs, each managed by a powerful DSP Engine.

The four input channels provide 30-band parametric EQ, Noise Gate, up to 420ms Delay and RMS Compressor.

Each of the 8 outputs offers 7-band parametric EQ, crossovers with slopes from 6dB/oct up to 48dB/oct, 128ms of Delay and Peak Limiter settings.

Easy setup is assured with intuitive front panel controls and an interactive LCD display for local setup, or a dedicated PC control interface for remote monitoring and configuration via USB or RS485.

The SP48 loudspeaker processor is the perfect counterpart to any HH speaker system, suitable in an array of applications, such as live sound, indoor/outdoor events, public address, theatrical performance, and touring.

It also comes pre-loaded with expertly created audio pre-sets for use with the TNA line array system, for easy setup straight out of the box.

## FEATURES

- High performance 4 input, 8 output loudspeaker processor.
- High quality 24bit AD/DA audio converters.
- 96bit DSP processor precision.
- USB port for simple programming and setup.
- Linkable inputs and outputs for easy stereo configuration.
- Switched mode power supply with 100-240V worldwide operation.
- 1U rack height

## GETTING STARTED

To quickly get started using the HH SP48 follow the following steps:

1. Make all initial connections with the power OFF on all equipment. Ensure any volume, level, or gain controls are at minimum.
2. Connect your signal source output to the inputs of the SP48.
3. Connect outputs 1-8 from the SP48 to the inputs of your power amplifiers or powered loudspeakers.
4. Starting at the signal source, turn on equipment.
5. As soon as the SP48 is turned ON the device model name will appear in the LCD screen

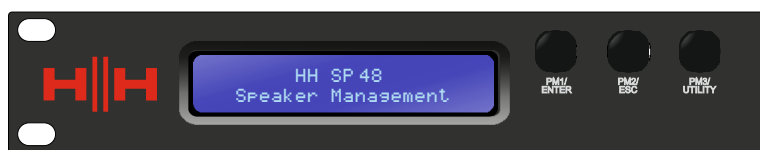

6. A status bar will show the progress of the SP48 initialization process



7. After the SP48 has finished it's boot up sequence, select the preset to best match your system setup.

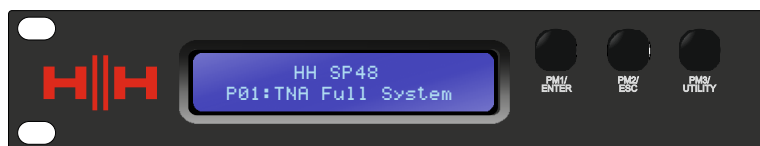
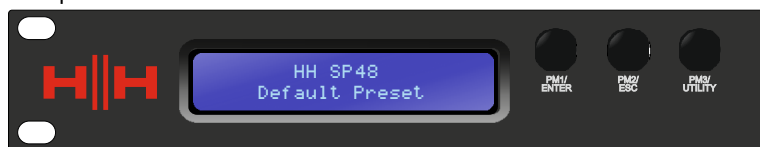

8. Turn on power amplifiers, powered loudspeakers, and the rest of the system.
9. Un-mute the input and output channels of the SP48.
10. Turn up the signal source until audio is heard through the system.

# CONNECTING THE SP48

Here are some example system connections for the SP48.

## Passive TNA System

In this example, the SP48 is setup to drive a passive TNA system using HH M-Series amplifiers. The four inputs come from a signal source such as a mixer or media stream. The first two outputs are driving the two TNA-1800s subs with a LF crossover. The next two are driving four TNA-1200S with two per channel for the mid band frequencies. Another two are driving 8 TNA-2051s and the last two are driving two TNi-W8PROs for balcony fills.

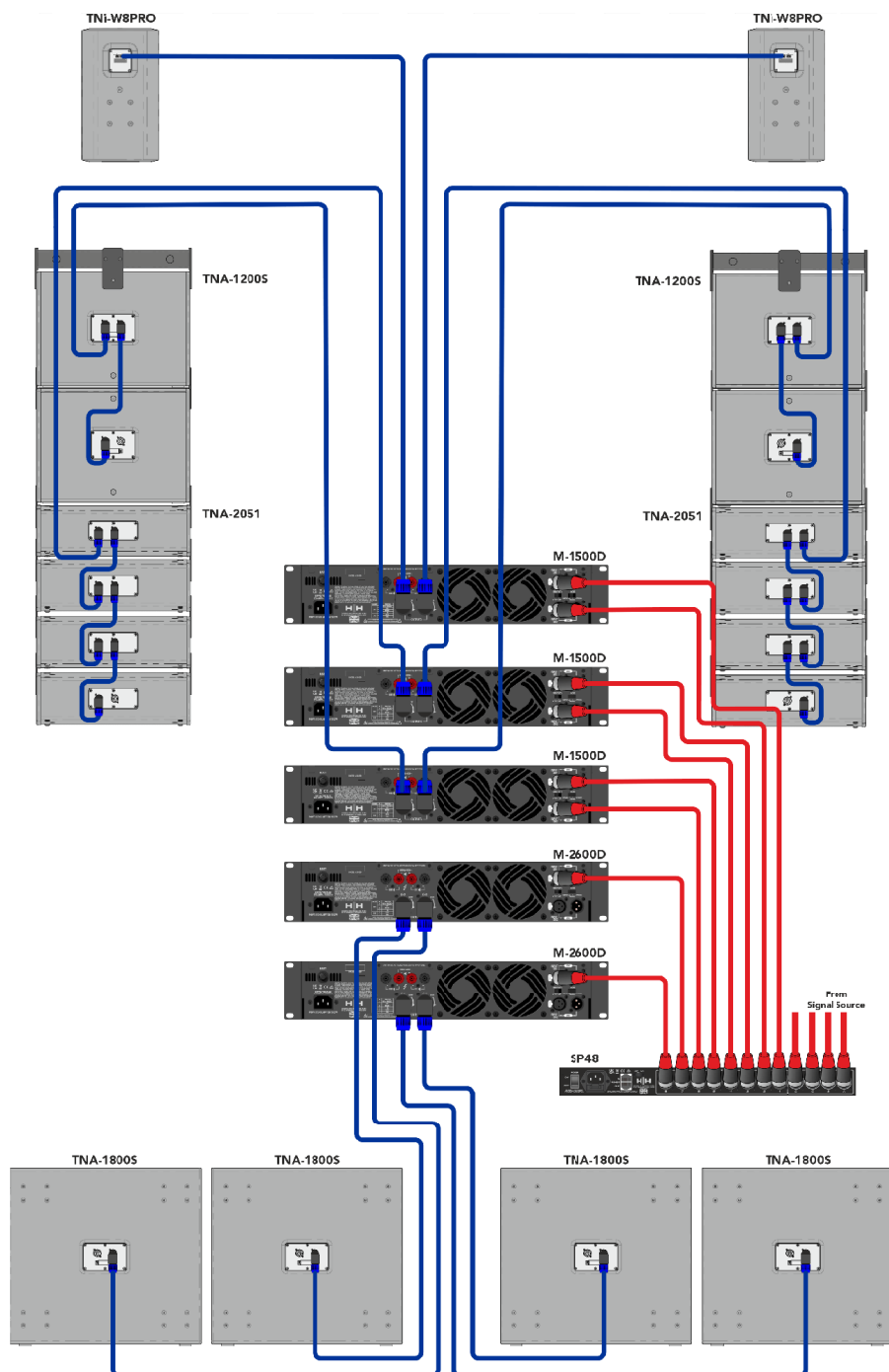

## Passive TNi-C6 System

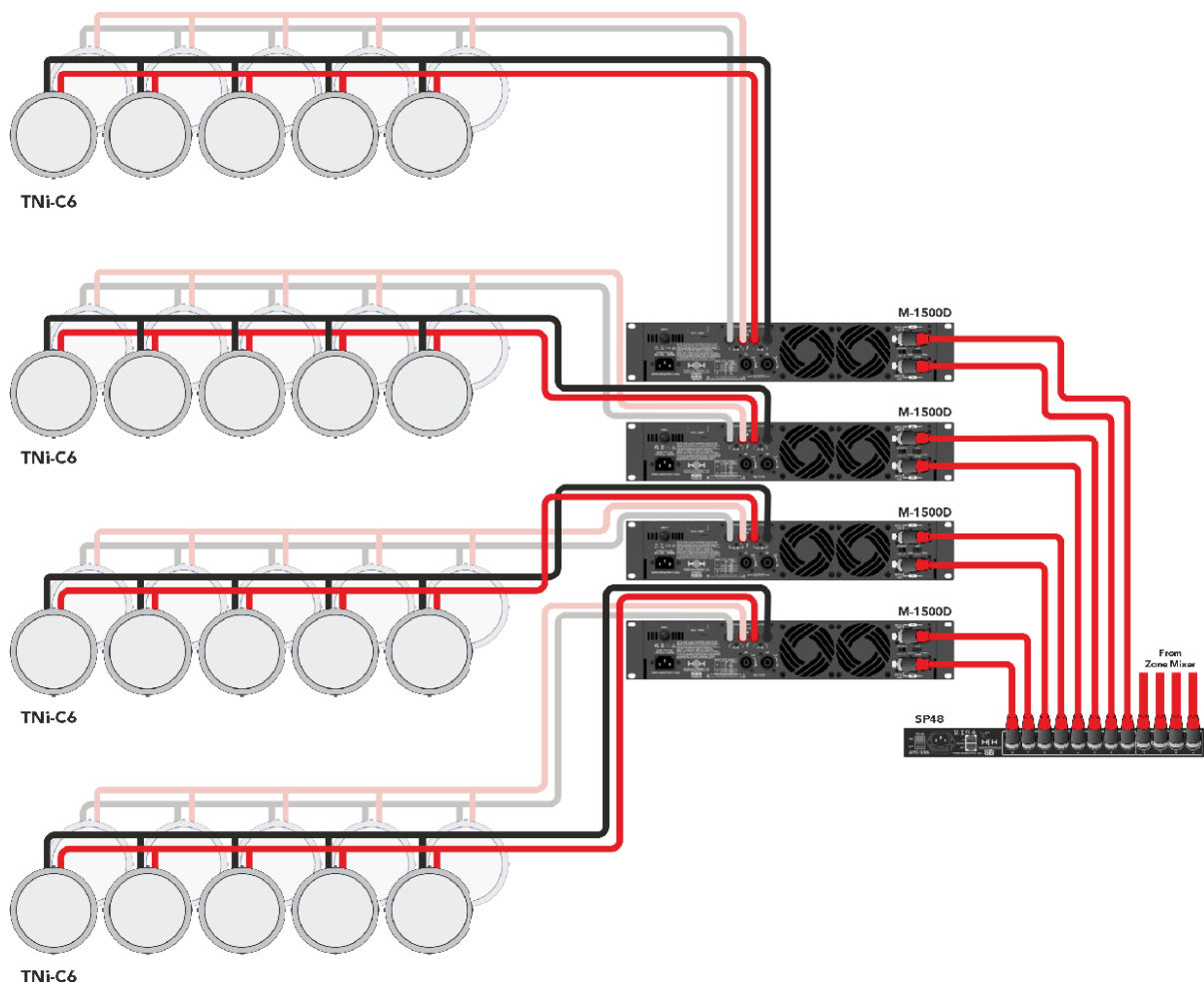

This setup shows the SP48 connected to 4 M-series amplifiers, which in turn are each connected to 10 TNi-C6s. The system shown here has various uses such as bars, cafes or offices and can be spread over multiple rooms.

## Active TNA System

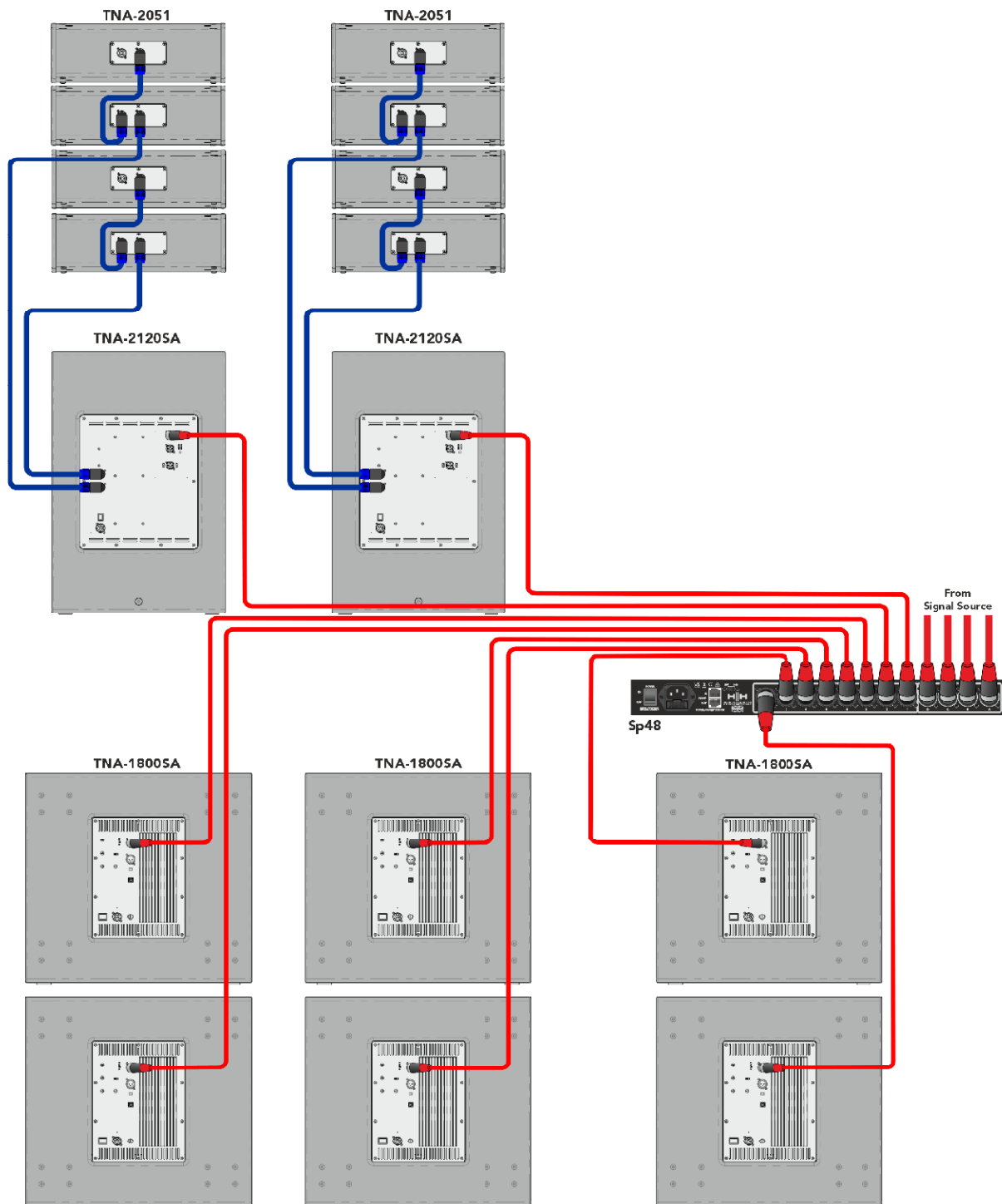

This example shows the SP48 driving into an Active TNA system with powered speakers. The first two channels are used to drive the TNA-2120SA MF to HF loudspeakers, these would receive a full range signal as the on-board DSP will handle crossover frequencies, this gives the SP48 more freedom for EQ adjustments to fit the room environment. The last six channels are used to drive six TNA-1800SA active subwoofers. Having independent channels for each sub-woofer allows for precise phase alignment.



## Mixed TNA System

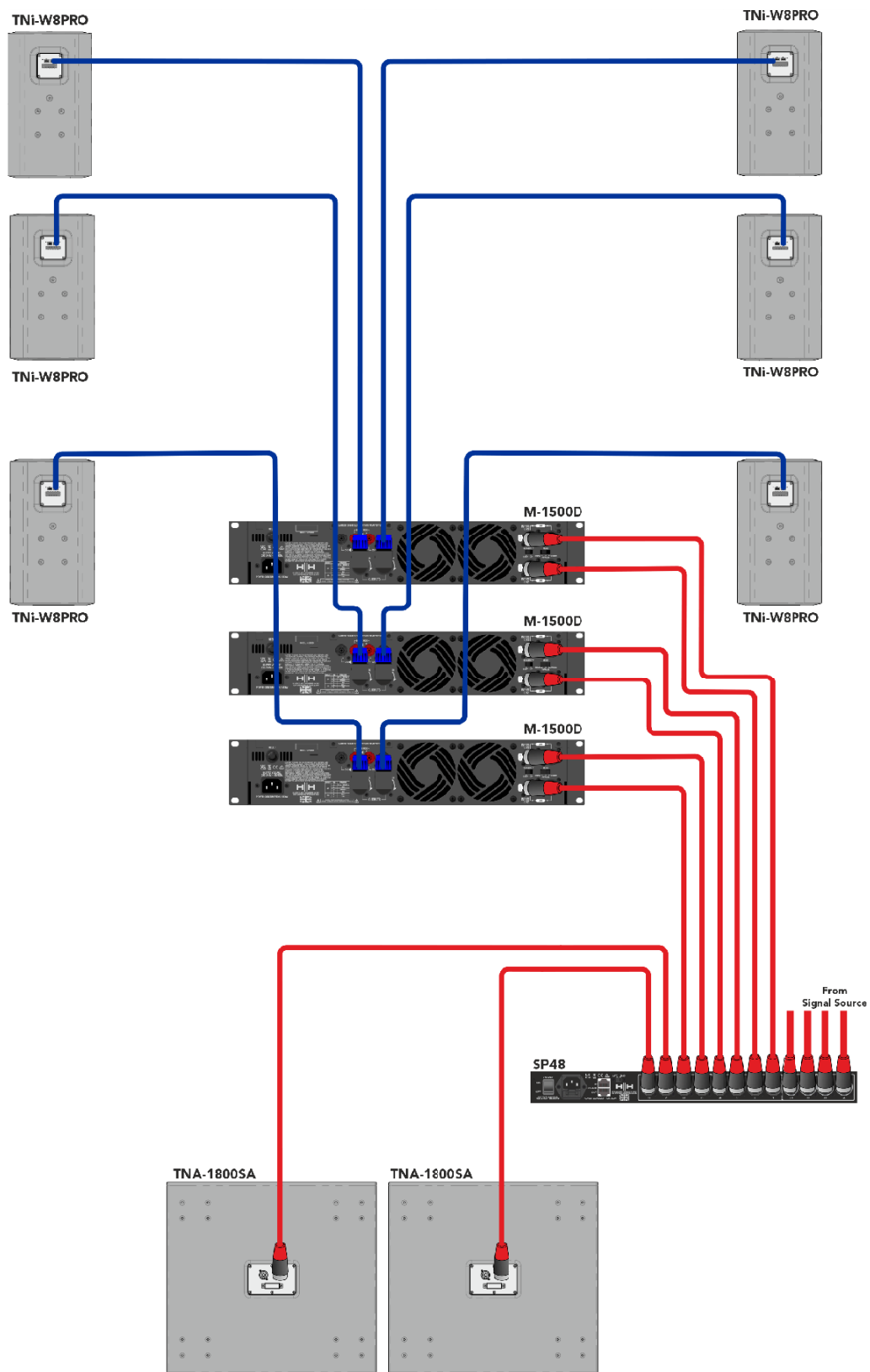

In this example the SP48 is setup for a mix of powered and passive loudspeakers. Two outputs are used to drive two TNA-1800SA powered sub-woofers. This leaves the remaining six outputs to drive 6 TNi-W8Pro via three M-1500A amps. This system could be extended with multiple subs and TNi-W8PROs to easily cover a bar or club venue.

# SP48 PROCESSOR OVERVIEW

## REAR PANEL

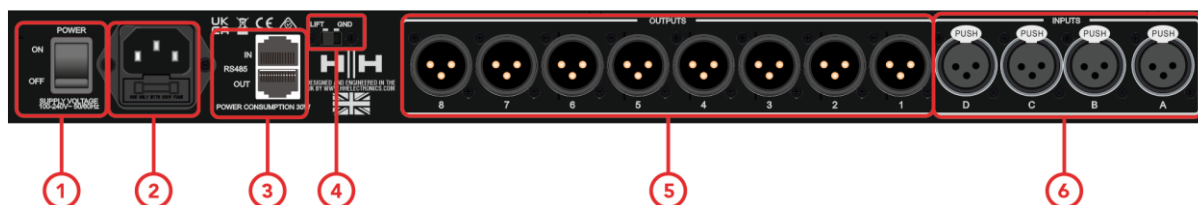

### 1. POWER SWITCH

Turns the HH SP48 on and off. When powering on or off the unit, the outputs and inputs will mute to avoid unwanted pops or noise, but it is still recommended to turn off / mute any power amplifiers or active loudspeakers connected to the SP48 before power cycling the unit.

### 2. MAINS INLET SOCKET & FUSE

This is where to connect the IEC power cable included with the SP48. The SP48 uses a SMPSU which allows for 100-240V~ Worldwide AC operation.

The FUSE is accessible from the holder. Only replace the fuse with the correct type and rating - T800mA L 250V

### 3. RS485 Connections

IN and OUT ethernet connections for RS-485 remote control and linking several units. Up to 32 SP48 can be connected in the same network. The RS-485 section also has its own GND lift switch if ground loop hum is induced via the RS-485 connections.

### 4. GND/LIFT

If you are getting ground loop hum from the RS-485 connections, you can use the GND/LIFT in attempt to remedy it.

### 5. XLR OUTPUTS

Eight line-level balanced male XLR outputs for each of the processor's channels. Connect these to inputs of power amplifiers and/or active loudspeakers.

### 6. XLR INPUTS

Four line-level balanced female XLR inputs for input channels A, B, C and D. Connect these to the main mixer outputs or other audio source.

## FRONT PANEL

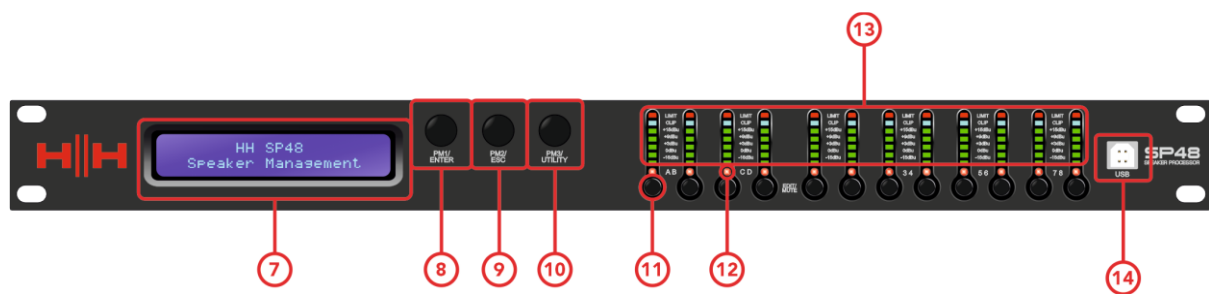

### 7. LCD

The main LCD display works in conjunction with the NAV controls and can be used to access and edit the local SP48 configuration settings. This is useful if not using the control app to configure the processor or to make quick adjustments.

### 8. PM1/ENTER

The **[PM1/ENTER]** control is a rotary encoder used for editing parameter values as well as a button to enter submenus and confirm operation changes.

### 9. PM2/ESC

The **[PM2/ESC]** control is a rotary encoder used for editing parameter values as well as a button to leave submenus and cancel operation changes.

### 10. PM3/UTILITY

The **[PM3/UTILITY]** control is a rotary encoder used for editing parameter values as well as a button to enter the sub-menus for setting the general characteristics of the processor

### 11. EDIT/MUTE BUTTONS

The 12x MUTE / EDIT buttons have two modes of operation. They allow selection for editing and control the mute status of the 4 inputs and 8 outputs.

A short press selects the relevant input or output channel for editing. This will illuminate the LED of the selected channel blue; a second press will deselect the channel and bring it out of edit mode. It is possible to select multiple inputs or outputs at once for simultaneous editing.

A long press enables or disables the mute for the input or output channel. This will illuminate the LED red to indicate the relevant channel is muted. Press and hold until the MUTE LED is cleared to enable the channel again.

### 12. EDIT/MUTE LEDs

12 LEDs referring to each input or output. A blue light indicates the selected channel/s are being edited. A red light indicates the selected channel/s are muted.

### 13. METERS

The METER LED displays show current signal level for the input and output. For optimal headroom these meters should remain green. The occasional peak enabling the yellow

"LIMIT" LED is viewed as ok. Constant illumination of the LIMIT LED or the red CLIP LED shows the signal level is too high and should be lowered.

*Note Internal Gain and EQ settings can also cause the signal to increase in level, in general it is better to cut than to boost excessively*

The input meters show:

CMP, CLIP, +15dBu, +9dBu, +3dBu, 0dBu, -25dBu

The output meters show:

LIMIT, CLIP, +15dBu, +9dBu, +3dBu, 0dBu, -25dBu

## **14. USB**

For more convenient control of the SP48, you can use any Microsoft Windows® based PC by connecting via the USB cable supplied.

## **Encoders, Enter and ESC buttons**



The HH SP48 is equipped with 3 Relative Encoders, PM1/ENTER, PM2/ESC and PM3/UTILITY. These encoders allow you to navigate the user interface and edit sections of the processor. The PM1/ENTER rotary encoder is used to navigate menus and sub-menus as well as confirm changes. The PM2/ESC and PM3/UTILITY encoders allow editing of selected parameters as well as exiting/cancelling settings and entering the utility menu.

## FACTORY RESET

In the event of the password being lost or any other reason the user may require the unit to be reset to the original factory settings. The FACTORY RESET will clear all settings of the HH SP48 and return the device to the original factory setting.

**Note: A factory reset of the HH SP48 will mean any user settings or previously stored information will be permanently lost.**

To perform a factory reset:

1. Whilst the unit is off, press and hold the ENTER, ESC & UTILITY buttons.
2. Power on the unit whilst holding these buttons.
3. The following LCD screen will appear:

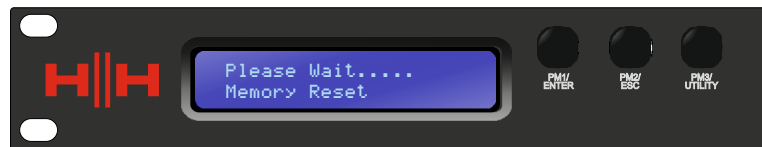

4. Release the buttons and wait for the factory reset to complete.

Regular operation as a completely new unit will resume once complete.

## UTILITIES

There are 4 utility menus to choose from:

- System Utilities
- Program Utilities
- Interface Utilities
- Security Utilities

To access any of the utility menus press the UTILITY button to open the menu.

Use the NAV/PM1 control to navigate the menu and sub-menus. ENTER and ESC buttons can be used to enter sub-menus or return to the home screen.

## SYSTEM UTILITIES

### Delay Units

Allows to select the measurement unit to be used for the Delay. The options are Time (in milliseconds) or Distance (in meters).

PM2 & PM3 - Change unit, Time(ms) and Distance(m).

### Set Default Value

Resets the current preset to the factory defaults.

### Firmware Version

Displays the current Firmware of the HH SP48.

## PROGRAM UTILITIES

This sub-menu allows you to access options related to the management of presets in the HH SP48. From this menu you can Recall, Save and Delete stored presets.

### Recall a Program

Allows loading of preset programs and settings. The HH SP48 can store up to 24 presets in the onboard memory. PM1 will scroll through available presets, if no user presets are found the display screen will show "No Stored Programs".

Press ENTER to recall a user preset and then ENTER again to confirm recalling the preset. The unit will mute whilst recalling a preset. More presets are available on our website.

### Save a Program

Allows to save the current settings into a preset slot. Use PM1 to scroll to the required slot to store the current settings. Selecting a slot with an existing user preset is possible, though a confirmation screen will appear to warn of overwriting.

After ENTER is pressed a preset name is required. Use PM1 to select the character position, PM2 & PM3 to select the character. Press ENTER once name entry is complete, and press ENTER again to confirm.

### Delete a Program

Allows to delete any of the stored presets on the HH SP48. Use PM1 to scroll to the preset to delete, and press ENTER to delete the selected preset.

**Warning: Deletion of presets is permanent and cannot be undone.**

## **INTERFACE UTILITIES**

The INTERFACE sub-menu is for remote control settings [USB or RS-485].

### **Interface Setup**

Allows you to define the remote-control interface [RS485] to be used for controlling the SP48.

If you would like to connect more than one unit under the RS485 mode, use PM2/PM3 to set any ID from 1 to 32 and confirm with enter to assign the connected units.

The remote control is available via the rear RS485 connector.



## SECURITY UTILITIES

A selection of security options to protect settings and to avoid tampering when the unit is used in public installations or for security systems.

### Show Parameter

Press ENTER button again and use the PM2 or PM3 encoders to select between “be shown” or “not be shown” options. Choosing the “be shown” option means that once the unit is locked, you cannot access parameter editing features, but they will be displayed on the LCD screen. Choosing the “not be shown” option means that once the unit is locked, the parameters will not be shown at all.

### Lock Unit

Allows the unit to be locked so no parameters can be edited or modified.

[ON] When lock is selected from the menu, the unit will be locked, and the lock menu automatically exits. The screen will revert to the default showing the current configuration. Additionally, a key icon will appear to indicate the SP48 is locked.

[OFF] Default setting. Parameters can be edited, and mutes changed.

### Change Password

The SP48 can be password protected to further add security and limitations to editing parameters. The User Password menu is used to set and change the password.

Press ENTER on the User Password menu to start. Use PM2 to move between locations and PM3 to choose the character. First, enter the existing password (the default is **[000000]**) and press ENTER again. Now input the new required password, press ENTER and re-enter the new password to confirm, pressing ENTER for the final time will update the stored password.

### Lock With Password

Like “Lock Unit”, allows the unit to be locked so no parameters can be edited or modified. In addition, the unit cannot be unlocked without a password input.

Press ENTER on the [Lock With Password] menu to start. Input the password (see [Change Password](#) section for how to change) and press enter to lock the SP48.

To unlock the unit press UTILITY and enter the password. If the password is ever lost or the unit is locked out, a factory reset can be used to gain access back into the unit.

## EDITING

Changing parameters on the SP48 is possible via the front panel controls. The following sections will cover the parameters available for control for both the input channels and output channels.

On the front panel pressing any of edit buttons will allow parameter modification, a long press with enable / disable the channel mute. Multiple parameter changes across channels are also possible, see

[LINKING INPUTS AND OUTPUTS.](#)

## INPUTS A/B/C/D

The HH SP48 has 4 XLR inputs best suited for line level inputs. The inputs are labelled A, B, C and D.

On the front panel pressing any of the four-input mute/edit buttons will allow parameter modification, a long press will enable / disable the channel mute.

The signal path for the four channels is as follows:

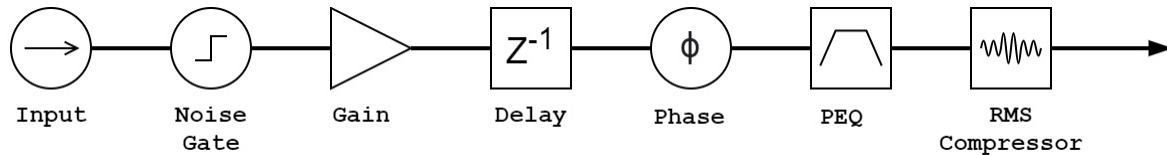

## Name

This menu gives the possibility to assign an input channel a name with up to 6 characters. Pressing ENTER will begin the editing process, use PM2 to select the character and PM3 to change the character. Press ENTER to confirm the new name of the input channel.

## Noise Gate

The SP48 comes with a noise gate for each input channel. This can be useful for removing any low-level input noise, such as electrical hum. Pressing ENTER will open the submenu which contains 4 settings for the noise gate. Use PM1 to navigate the 2 pages.

Page 1 - Bypass & Threshold

**[Bypass]** PM2 controls the bypass setting for the noise gate. Setting the noise gate to ON will disable the noise gate from the signal path. Toggling on and off is useful for comparing both affected and un-affected signal.

**[Thr]** PM3 controls the threshold level in dBu. Signals below the threshold value will be muted by the noise gate, signals above the threshold will be un-affected. The value range can be from -80dBu to -50dBu.

Page 2 - Attack & Release

The attack and release settings change how quickly the noise gate re-acts to changing signal level. The attack setting controls how fast the noise gate mutes the signal once it drops below the threshold. The release settings controls how fast the noise gate un-mutes the signal once it rises above the threshold.

**[Rel]** The release setting for the noise gate is set by PM2. Value range is 10ms - 1,000ms.

**[Atk]** The attack setting for the noise gate is set by PM3. Value range is 1ms - 1,000ms.

## Gain

Each input channel has independent gain control. Press ENTER to begin editing the Gain. PM2 will change the gain in increments of 1.0dB and PM3 will change the gain in increments of 0.1dB. Press ESC to exit the gain editing mode.

**[Gain]** Value ranges from -18dB to +12dB in 0.1dB steps.

## Delay

The SP48 input delay is useful for time aligning multiple system components together, time aligning the system to live instruments, time aligning systems with videos and more. The delay setting can be displayed in two formats: distance (in meters) and time (in milliseconds). The display unit is set in the **[SYSTEM UTILITIES > Delay Units]** menu.

PM2 controls the coarse adjustment of the delay time, and PM3 controls the fine adjustment of the delay time. The available delay ranges are:

Time: 0ms ~ 420.9984ms

Distance: 0m ~ 143.139m

## Polarity

The phase of the SP48 inputs can also be altered. Press ENTER to change the setting, and then the polarity of the input can be set to either

**[Normal]** 0° phase shift

**[Invert]** 180° phase shift

## RMS Compressor

The input channels on the SP48 have an RMS compressor which can be enabled. The compressor reacts to the RMS (Root Mean Squared) level of the signal, this is an average measurement so reaction time and changes will be more gradual than a peak Limiter. RMS compression is typically more subtle, making it a good choice for music, voice and mix buses. Because it is acting upon an average of the signal it may cause transient or percussive peaks.

Press ENTER and use PM1 to navigate through the 5 submenus of the RMS Compressor.

Page 1 - Bypass

**[Bypass]** PM2/PM3 controls the bypass setting for the RMS Compressor. Setting the bypass to ON will disable the RMS Compressor from the signal path. Toggling on and off is useful for comparing both affected and un-affected signal.

Page 2 - Threshold

Sets the threshold level when the compressor will activate. When the compressor is active the yellow CMP led on the input meter will illuminate. PM2/PM3 changes the threshold value in 1.0dBu increments and PM3 allows for fine control in 0.1dBu increments.

**[Threshold]** Value ranges from -14dBu to +16dBu in 0.1dBu increments.

Page 3 - Ratio & Knee

Ratio controls the amount of compression applied to the signal over the threshold amount. A setting of 2:1 will mean a signal of 2dBu RMS over the threshold will be attenuated by 1dBu. Higher setting means higher attenuation.

Knee controls the transition from uncompressed to compressed signal. A hard knee setting (0%) means as soon as the signal level crosses the threshold the full ratio will be applied. A softer knee (> 1%) means there is a transition from crossing the threshold before the full compression ratio is applied. A hard knee is more distinct whereas a softer knee allows for smoother and more gradual transitions into compression.

**[Ratio]** Controlled by PM2, value ranges from 2:1 to 32:1.

**[Knee]** Controlled by PM3, value ranges from 0% - 100%.

Page 4 - Attack and Release

The attack and release settings change how quickly the compressor reacts to the signal crossing the threshold level. The attack settings controls how fast the compressor triggers when the signal level crosses above the threshold. The release setting controls how fast the compressor stops attenuating the signal once it drops below the threshold.

**[Rel]** The release setting for the noise gate is set by PM2. Value range is 0.1s to 3s

**[Atk]** The release setting for the noise gate is set by PM3. Value range is 5ms to 200ms.

Sets the post gain applied to the signal after the RMS compression

**[Make-up]** Controlled by PM2/PM3 and has a range of -12dBu to +12dBu

## EQ Bypass

The 30 Band PEQ can be bypassed to help show how the EQ parameters are affecting the system.

Press ENTER to edit the setting then PM2/PM3 to toggle between **[ON]** and **[OFF]**. This allows for a quick comparison of the sound with and without EQ.

## 30 Band EQ [EQ-01 -> EQ-30]

The SP48 has a 30 band EQ for all four of the input's channels. These are useful for adjusting the entire systems response, a common use is for acoustical room corrections. This allows the user to edit the input EQ for the room whilst leaving the output EQ for cabinet EQ.

Press ENTER and use PM1 to navigate through the submenus of the Band EQ.

**[Bypass]** Using PM2 to enable or disable the individual EQ band.

**[Type]** Using PM3 the EQ band type can be set. The three choices for EQ type are:

- **[Peaking\_Eq]** - A parametric peak filter with adjustable Q.
- **[Hi-Shelv]** - A high shelving filter. Choose preset 1, 2 or Q which is adjustable
- **[Lo-Shelv]** - A low shelving filter. Choose preset 1, 2 or Q which is adjustable
- **[Low-Pass]** - A low pass filter. Choose preset 1, 2 or Q which is adjustable
- **[High-Pass]** - A high pass filter. Choose preset 1, 2 or Q which is adjustable
- **[Band-Pass]** - A band pass filter for allowing a range of frequencies through.
- **[Notch filt]** - A notch filter for blocking particular frequencies.
- **[All Pass]** - An all-pass filter with a flat frequency response and can provide a phase switch. Choose between 1, 2 presets.

**[Freq]** Allows to set the EQ bands centre frequency from 20Hz - 20,000Hz. Use PM2 to change the value in 100Hz increments and PM3 to change by 1Hz increments.

**[Gain]** The PM2 control changes the gain of the EQ band by 0.5dB per increment. Turning clockwise increases the gain and vice versa. Each band has a gain range of -15dB to +15dB.

Note: **[Low-Pass 1,2,Q]**, **[High-Pass 1,2,Q]**, **[Notch Filt]** and **[All Pass 1,2]**, the gain is fixed.

**[Q]** The PM3 control changes the Q factor of the EQ. For filters with a 1 or 2 in the title bar **[All Pass 2]**, the Q factor is fixed by the preset.

When the type is set to **[Peaking\_Eq]** the Q factor controls the bandwidth of the peaking eq. The allowed values range from 0.40 to 128.

For **[Hi-Shelv Q]**, **[Lo-Shelv Q]**, **[Low-Pass Q]** and **[High-Pass Q]** the Q factor controls the slope of the filter, the lower the value the shallower the slope, and vice versa. Ranges between 0.1 to 5.1 and values above 1.00 will begin to cause overshoot.

For **[Band Pass]**, **[Notch Filt]** and **[All Pass 2]**, the filter has a range of 4 to 104.

## OUTPUTS 1~8

The HH SP48 has 8 XLR outputs for driving power loudspeakers, amplifiers, and other sources. A maximum output of +21dBu is available. The outputs are labelled 1 to 8 by default and can be changed by the user.

On the front panel pressing any of the output channel edit buttons will allow parameter modification, a long press will enable / disable the channel mute.

The signal path for both output channels is as follows:

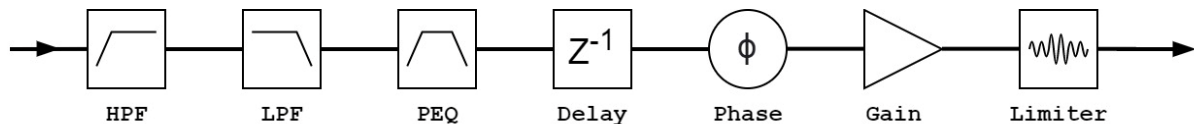

### Name

This menu gives the possibility to assign an output channel a name with up to 6 characters. Pressing ENTER will begin the editing process, use PM2 to select the character and PM3 to change the character. Press ENTER to confirm the new name of the output channel.

### Routing Page

The SP48 supports full matrix mixing for the four input channels per output. The source sub menu allows the selection of signal source to the output channel. Pressing ENTER will enter the source selection menu, use PM1 to navigate between the pages for input A/B/C/D, PM2 to choose the level of selected input and PM3 to turn the input on or off.

### Gain

Each output channel has independent gain control. Press ENTER to begin editing the Gain. PM2 will change the gain in increments of 1.0dB and PM3 will change the gain in increments of 0.1dB. Press ESC to exit the gain editing mode.

**[Gain]** Value ranges from -18dB to +12dB.

### Delay

The SP48 output delay is useful for time and phase aligning speaker systems, for instance, aligning bi-amplified loudspeakers or aligning subwoofers to full-range speakers. The delay setting can be displayed in two formats: distance (in meters) and time (in milliseconds). The display unit is set in the **[SYSTEM UTILITIES > Delay Units]** menu.

PM2 controls the coarse adjustment of the delay time, and PM3 controls the fine adjustment of the delay time. The available delay ranges are:

Time: 0ms ~ 128.9984ms

Distance: 0m ~ 43.520m



## Polarity

Each output channel has a phase control to easily swap the polarity of the output signal. Press ENTER to change the phase mode. PM2 / PM3 will change between a 0° phase shift **[Normal]** and 180° phase shift **[Invert]**. Press ESC to exit the phase mode. This is useful to combine with the delay settings to ensure phase coherence of speakers in a system.

## LIMITER

The output limiter is similar to the input RMS compressor in function. This is a good choice if the amplifier or loudspeaker of the system already has a peak limiter, this will allow for more subtle and natural compressor of system.

Press ENTER and use PM1 to navigate through the 3 submenus of the RMS Compressor.

### Page 1 - Bypass

**[Bypass]** PM2 controls the bypass setting for the RMS Compressor. Setting the RMS Compressor to ON will disable the RMS Compressor from the signal path. Toggling on and off is useful for comparing both affected and un-affected signal.

### Page 2 - Threshold

Sets the threshold level when the compressor will activate. When the compressor is active the yellow LIMIT led on the output meter will illuminate. PM2 changes the threshold value in 1.0dBu increments and PM3 allows for fine control in 0.1dBu increments.

**[Threshold]** Value ranges from -14dBu to 16dBu in 0.1dBu increments.

### Page 3 - Attack and Release

The attack and release settings change how quickly the compressor reacts to the signal crossing the threshold level. The attack settings controls how fast the compressor triggers when the signal level crosses above the threshold. The release setting controls how fast the compressor stops attenuating the signal once it drops below the threshold.

**[Rel]** The release setting for the noise gate is set by PM2. Value range is 0.1s to 5s

**[Atk]** The release setting for the noise gate is set by PM3. Value range is 1ms to 900ms.

## HPF

Set and enable a high pass filter for the output selected. Press ENTER to enter the first submenu and PM1 to navigate submenus.

**[F]** Frequency of the high pass filter, value ranges from 20Hz to 20,000Hz. PM2 changes the value in steps of 100Hz, PM3 changes the value in steps of 1Hz.

**[Slope]** Use PM2/PM3 to select the desired high pass filter slope. Filter slope options include:

Bypass (HPF disabled)

Butterworth -6dB/Oct, -12dB/Oct, -18dB/Oct, -24 dB/Oct, -36 dB/Oct, -48 dB/Oct.

Linkwitz-Riley -12 dB/Oct, -24 dB/Oct, -36 dB/Oct, -48 dB/Oct.

Bessel -12 dB/Oct, -24dB/Oct.

## LPF

Set and enable a low pass filter for the output selected. Press ENTER to enter the first submenu and PM1 to navigate submenus.

**[F]** Frequency of the low pass filter, value ranges from 20Hz to 20,000Hz. PM1 changes the value in steps of 100Hz, PM2 changes the value in steps of 1Hz.

**[Slope]** Use PM3 to select the desired low pass filter slope. Filter slope options include:

Bypass (LPF disabled)

Butterworth -6dB/Oct, -12dB/Oct, -18dB/Oct, -24 dB/Oct, -36 dB/Oct, -48 dB/Oct.

Linkwitz-Riley -12 dB/Oct, -24 dB/Oct, -36 dB/Oct, -48 dB/Oct.

Bessel -12 dB/Oct, -24dB/Oct.

## EQ Bypass

The 7 Band PEQ can be bypassed to help show how the EQ parameters are affecting the system. Toggling between **[ON]** and **[OFF]** allows for quick comparison of the sound with and without EQ.

## 7 Band EQ [EQ-01-> EQ-07]

Press ENTER and use PM1 to navigate through the 3 submenus of the 7-Band EQ.

Page 1 - Bypass & Type

**[Bypass]** Using PM2 to enable or disable the individual EQ band.

**[Type]** Using PM3 the EQ band type can be set. The three choices for EQ type are:

**[Peaking\_Eq]** - A parametric peak filter with adjustable Q.

**[Hi-Shelv]** - A high shelving filter. Choose preset 1, 2 or Q which is adjustable

**[Lo-Shelv]** - A low shelving filter. Choose preset 1, 2 or Q which is adjustable

**[Low-Pass]** - A low pass filter. Choose preset 1, 2 or Q which is adjustable

**[High-Pass]** - A high pass filter. Choose preset 1, 2 or Q which is adjustable

**[Band-Pass]** - A band pass filter for allowing a range of frequencies through.

**[Notch filt]** - A notch filter for blocking particular frequencies.

**[All Pass]** - An all-pass filter with a flat frequency response and can provide a phase switch. Choose between 1, 2 presets.

Page 2 - Frequency

**[Freq]** Allows to set the EQ bands centre frequency from 20Hz - 20,000Hz. Use PM2 to change the value in 100Hz increments and PM3 to change by 1Hz increments.

Page 3 - Gain & Q (Bandwidth / Slope)

**[Gain]** The PM2 control changes the gain of the EQ band by 0.5dB per increment. Turning clockwise increases the gain and vice versa. Each band has a gain range of -15dB to +15dB.

Note: **[Low-Pass 1,2,Q]**, **[High-Pass 1,2,Q]**, **[Notch Filt]** and **[All Pass 1,2]**, the gain is fixed

**[Q]** The PM3 control changes the Q factor of the EQ. For filters with a 1 or 2 in the title bar **[All Pass 2]**, the Q factor is fixed by the preset.

When the type is set to **[Peaking\_Eq]** the Q factor controls the bandwidth of the peaking eq. The allowed values range from 0.40 to 128.

For **[Hi-Shelv Q]**, **[Lo-Shelv Q]**, **[Low-Pass Q]** and **[High-Pass Q]** the Q factor controls the slope of the filter, the lower the value the shallower the slope, and vice versa. Ranges between 0.1 to 5.1 and values above 1.00 will begin to cause overshoot.

For **[Band Pass]**, **[Notch Filt]** and **[All Pass 2]**, the filter has a range of 4 to 104.

## **LINKING INPUTS AND OUTPUTS**

It is possible to link inputs and outputs together to allow multiple channels to be edited at once. To edit multiple channels at once, first select the first channel with the EDIT/MUTE button, this channel will dictate the settings, then select each other channel that editing is required.

Pressing the first channel's EDIT button will exit the editing of all channels selected.

Note: Inputs and outputs cannot both be linked for editing

## USING THE CONTROL APP

The SP48 can be remotely setup via USB using our Windows® Control App. The following information shows how to install and use the SP48 speaker management software.

### Installation

To download the SP48 speaker management software visit the SP48 product page on our website at [HHELECTRONICS.COM](http://HHELECTRONICS.COM). Once downloaded run the software installer.

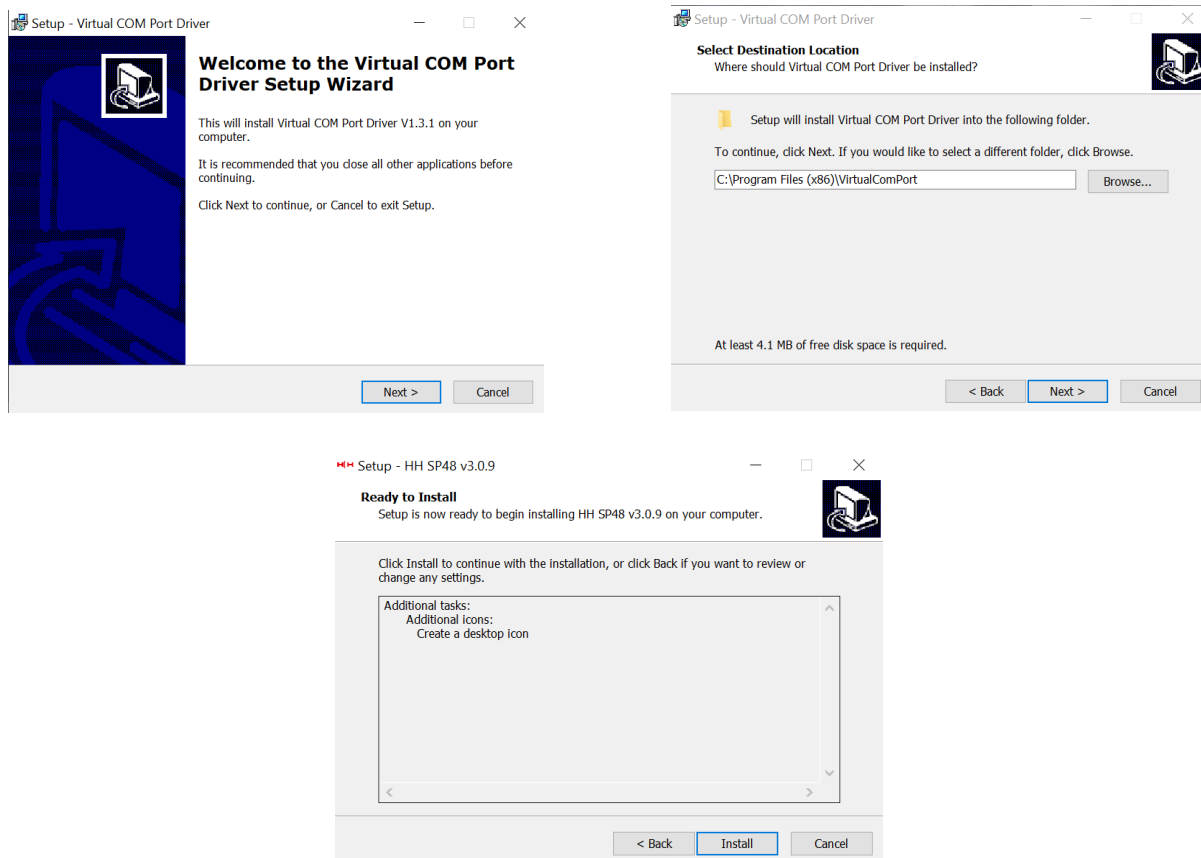

Choose the directory where you would like to install software, press next and final install.

After the main installation is complete a driver setup should follow. This is for the USB connectivity to the SP48. On the window click "INSTALL" and wait for the driver installation to complete.

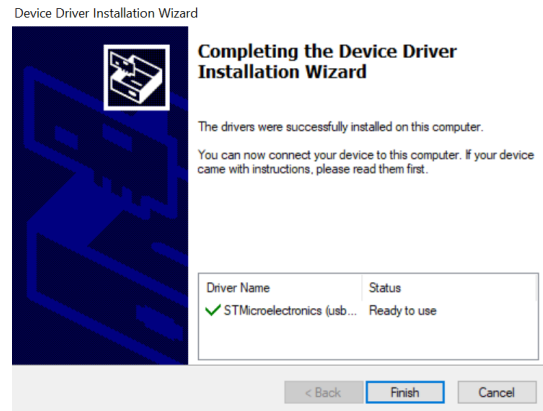
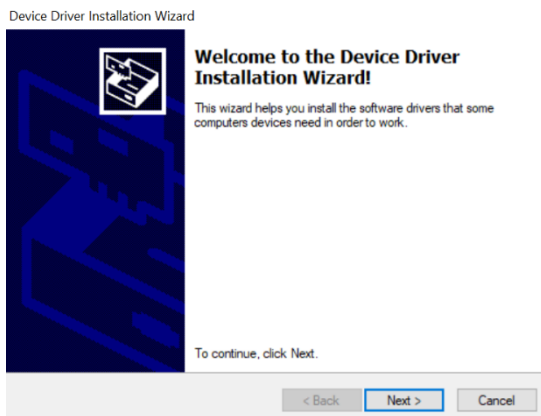

The SP48 speaker management software is now successfully installed.



## Connecting to Device

There are two options to connect to an SP48 remotely.

### USB

To connect to a unit via USB, connect a USB cable to the front port of the SP48 and the other end to the computer. Turn on the unit, on first connection you may see a popup mentioning driver installation.

Open the SP48 speaker management software and click "Connect". Select USB under communication port and click "Check" to list all available COM ports.

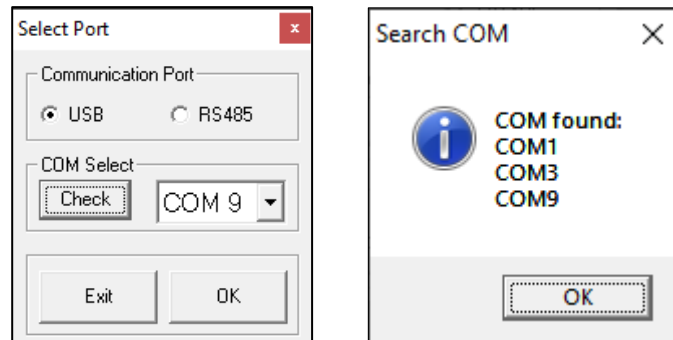

Select the correct COM port and click OK

Note: To find the correct COM to use check device manager under "Ports (COM & LPT)", the SP48 should appear as USB-SERIAL CH340 and give a COM port number.

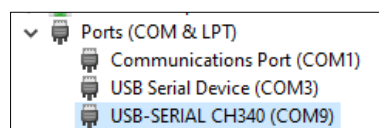

The connected SP48 will appear in the List ID window:



Double click the SP48 to load the current settings and to take remote control of the unit.

## RS485

Another method of connecting to the SP48 for remote control is via the RS-485 protocol. Set the SP48 **[INTERFACE > Interface Setup]** to RS-485 and connect a USB-485 adaptor to the RS-485 input on the rear panel (not included).

Using a USB-485 adaptor will require you to wire an RS-485 cable into the adaptor itself.

The image below shows the wiring for a standard Cat-5 cable:

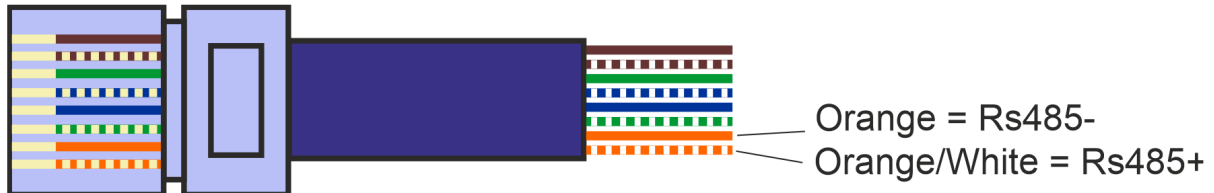

Connect the orange (negative) and orange and white (positive) cables to the transmit negative (T/R-) and transmit positive (T/R+) of the adaptor respectively. The rest of the cables can be ignored. Make sure the screws are tight and the cables won't fall out and that there are no connections between the unused cables, then this can be connected to the RS-485 IN on your SP48.

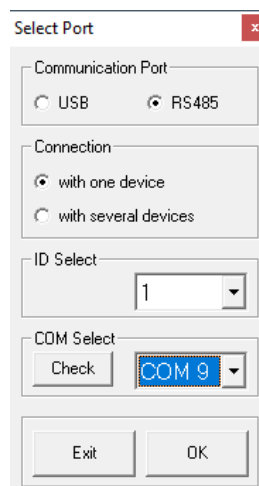

Making sure the SP48 is powered on, click connect and set the Communication Port to RS-485. Select "with one device" and the correct ID. Select the correct COM port of the USB to RS-485 device and click connect.





## Multiple connections

It is possible to control multiple (up to 32) SP48 speaker processors at once using the RS-485 interface.

Set the SP48 [\[INTERFACE > Interface Setup\]](#) to RS-485 and ensure each SP48 has a unique ID selected. Select the "with several devices option in the select port menu and choose the ID of the first SP48 connected to your PC.

Wire the SP48 units together like shown:

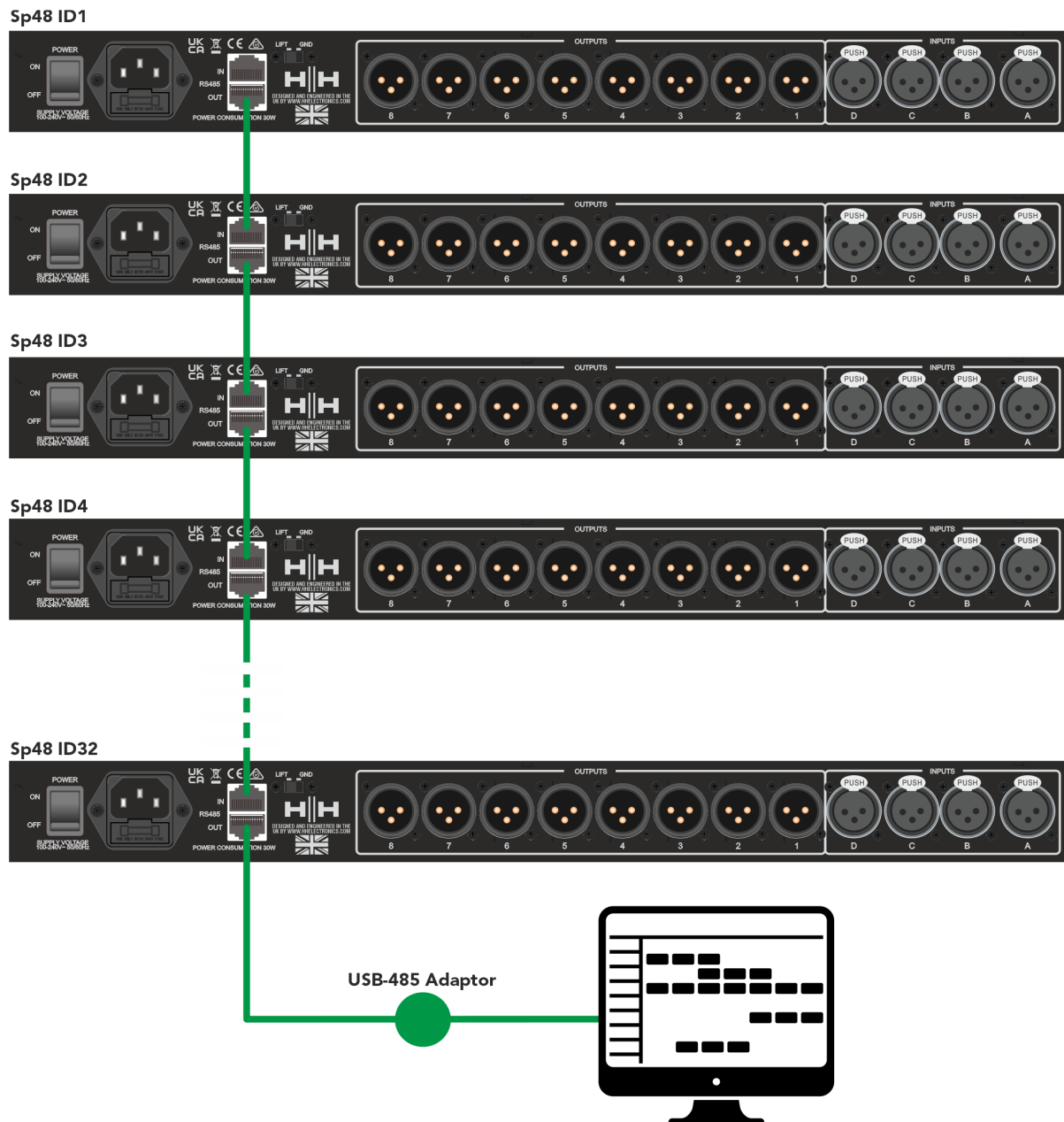

Click connect and set the Communication Port to RS-485.

Select multiple devices and select the correct COM port of the USB to RS-485 device. Click connect and the SP48 speaker management software will scan and connect to each SP48 chained together in the network. Each individual device will show up in the List ID menu.

**Note: Make sure to set the individual IDs on each SP48, making sure none are the same**

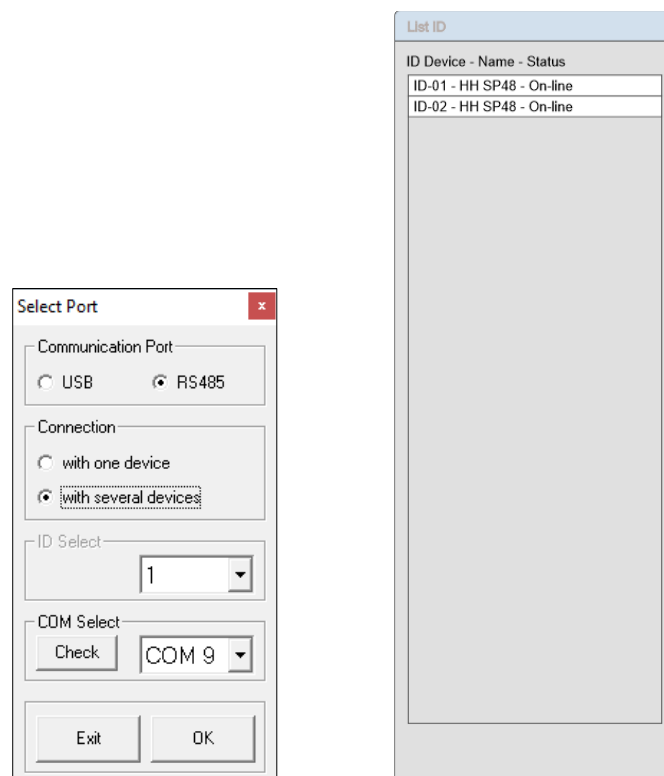

## DEMO MODE

If a device cannot be found, a warning will be show asking if you wish to enter demo mode.

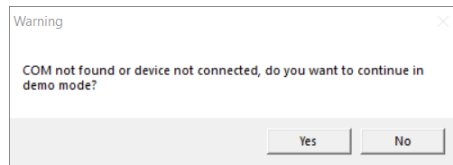

Demo mode allows full operation without having to connect the hardware so settings can be changed in advance.

## Rout Screen

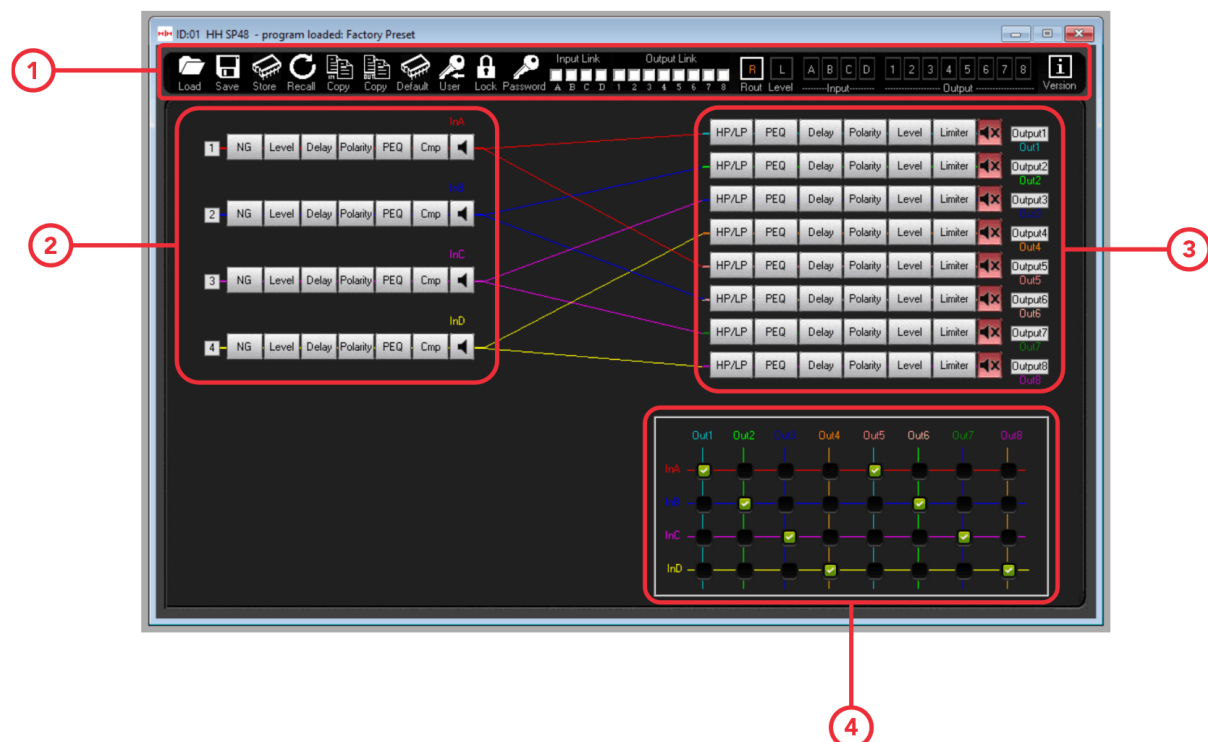

### 1. Program menu panel

File settings on the top left of the panel to make changes to the save file. Use the link check boxes in the middle to link inputs or outputs together for changing settings over multiple channels. Navigation panel on the right to move between settings for the inputs/outputs as well as view the full signal path as is on the image above.

### 2. Input Signal path

Shows an overview of the SP48 input signal path. Clicking any of the process buttons will display the relevant settings, also it is possible to control input mutes from here.

### 3. Output Signal path

Shows an overview of the SP48 output signal path. Clicking any of the process buttons will display the relevant settings, also it is possible to control output mutes from here.

#### 4. Input/Output linking

Choose which inputs go to which outputs by ticking/unticking the right boxes for your setup. This will change the coloured link lines in the middle of the screen to represent your setup.

**Note. When editing any parameters via the number input, to ensure the new value is applied to the processor press the "ENTER" key after inputting the new value.**

## Level Screen



5. Meter levels for each input and output. Shows dB levels of the channel as well as whether the limiter is active.

6. Controls the gain level for each input and output either from the slider or number box. From here you can also mute/unmute each channel as well as invert its polarity.

**Note: When editing any parameters via the number input, to ensure the new value is applied to the processor press the "ENTER" key after inputting the new value.**

## Input Screen

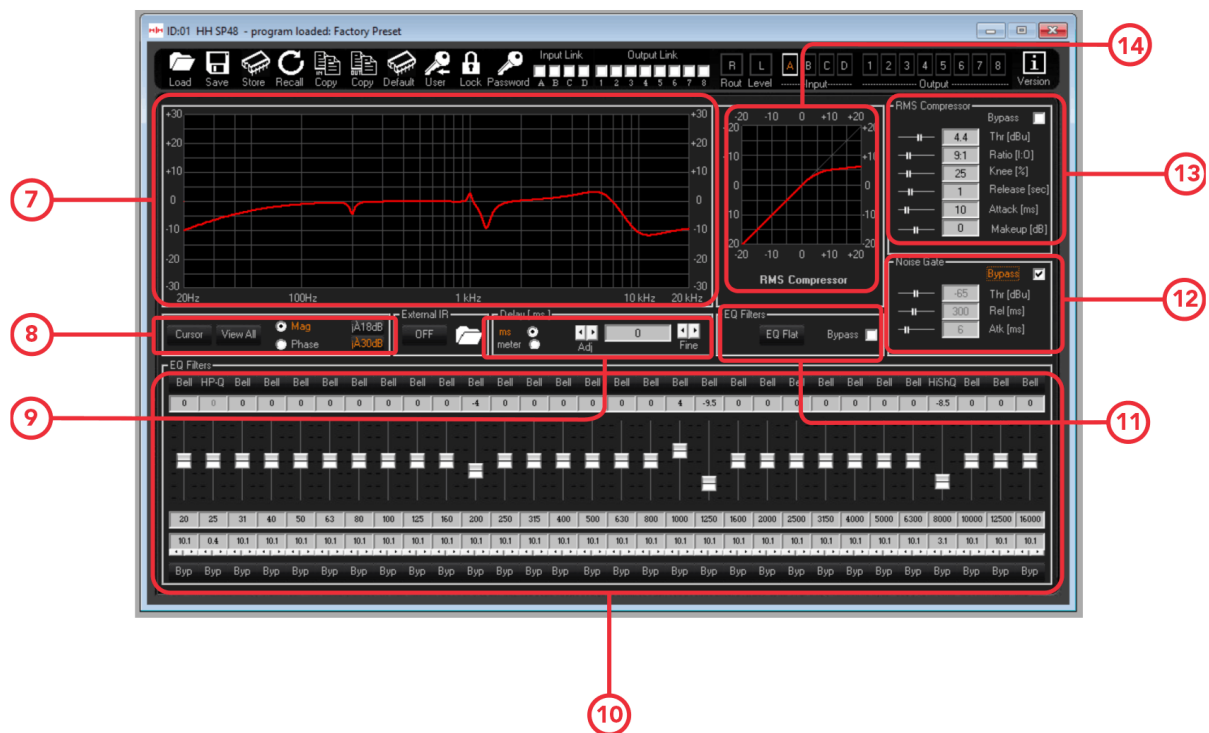

7. Shows the frequency response curve for the current input

8. Cursor and view options:

The **[Cursor]** button will toggle on and off the cursor control of the EQ points. When enabled you can use the mouse pointer to click and drag EQ points to set their parameters.

The **[View All]** button will display the View All Graph. See the View All Graph section for more details.

The **[Mag]** and **[Phase]** check boxes will change the frequency response display to a level (Magnitude) or phase display. The scale of the magnitude display can also be chosen between  $\pm 18\text{dB}$  and  $\pm 30\text{dB}$ .

9. Controls the delay of the input. Choose between ms or meter for units.

10. Controls the 30-band parametric EQ. Adjust each band individually, change the type at the top by clicking **[Bell]** (default of bell filter). Adjust gain, centre frequency and Q factor as well as the option bypass the band.

11. Controls the overall EQ filter settings. Reset all 30-band EQs with the **[EQ Flat]** button or choose to bypass the EQ.

12. Controls settings for the noise gate.

13. Controls the settings for the RMS compressor.

14. Shows the graph for the RMS response of the compressor.

## Output Screen

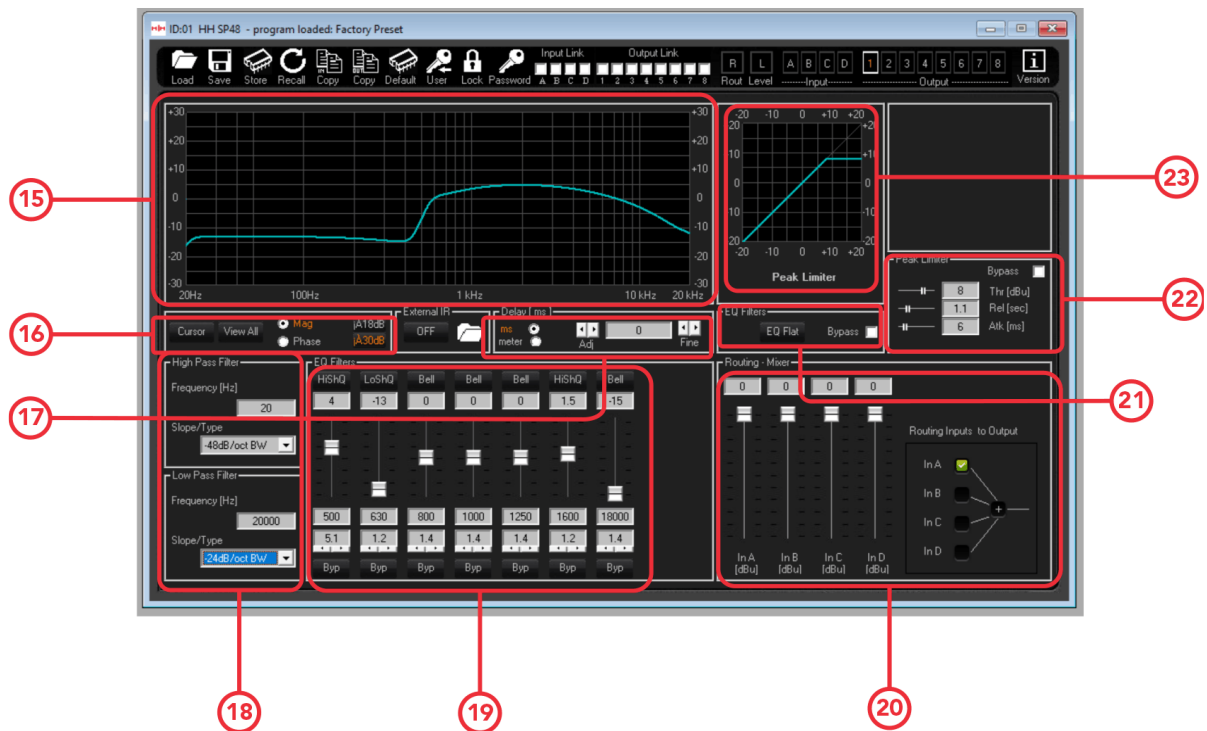

15. Shows frequency response curve for the 7-band parametric EQ
16. Cursor and view all options. These operate the same as the input channel.
17. Controls the delay for the selected output. Operates the same as the input channels.
18. Controls for the high-pass and low-pass filters at the selected output. Choose the Slope Type as listed in the [HPF/LPF section](#).
19. Controls for the 7-band parametric EQ for the selected output. Operates the same as the input 30-band PEQ.
20. Adjust the settings for the routing into the current output. View and edit what inputs are currently routed to this output as well as changing their levels.
21. Overall EQ filter setting for the output. Operates the same as the input EQ filters.
22. Controls the settings for the peak limiter.
23. View the response curve for the peak limiter.

## Editing channel names

To change and set any of the input or output channel names using the SP48 speaker management software, double click the name of the channel in the **[Gain Screen]** to bring up the Edit Names panel.

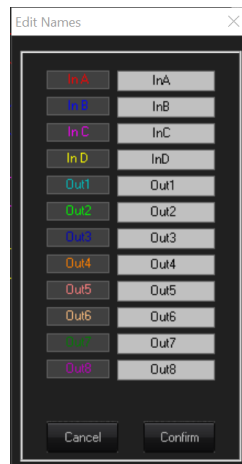

In this pop-up menu, you can alter any of the channel names. Press **[Confirm]** to apply changes, press **[Cancel]** to revert to the previous name(s).

## View All Graph

In the View All Graph window it is possible to overlay each EQ curve to view the entire processors response. Use the check boxes to enable or disable each Input and Output curve. Can also see the response of an output when paired with one of the input responses.

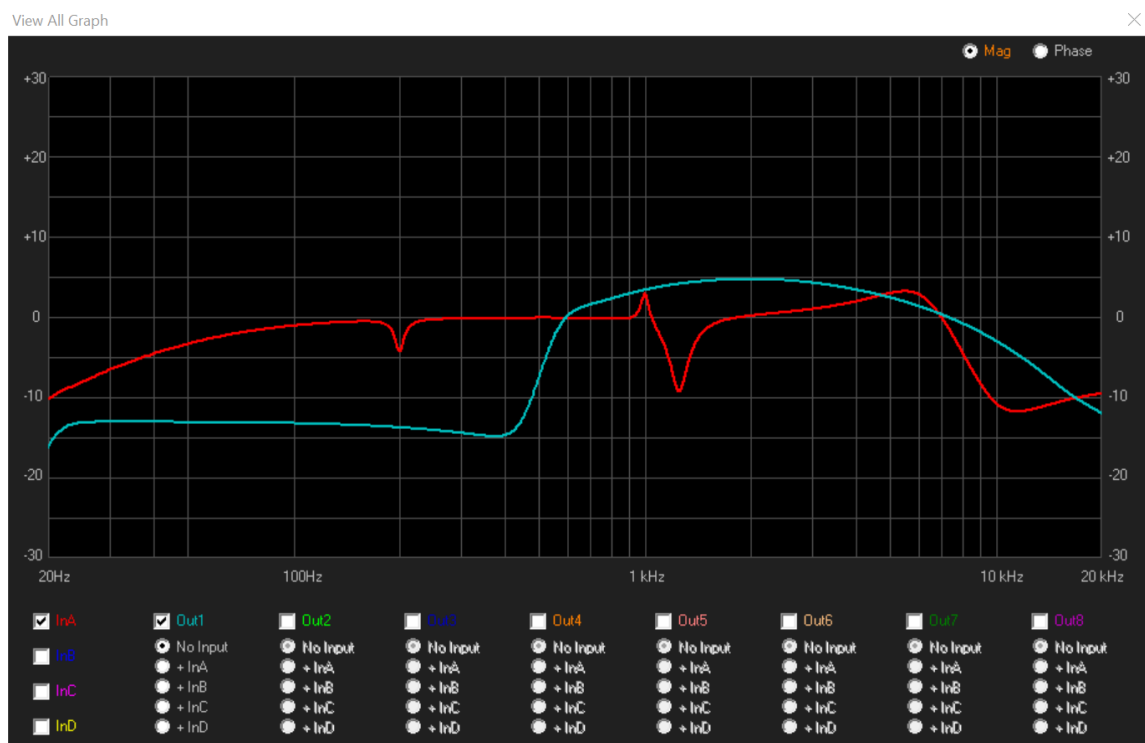



## MENU

The menu bar contains functions for preset management, settings, and security options for the SP48.



## LOAD

Click the **[LOAD]** button to load a preset from the computer.

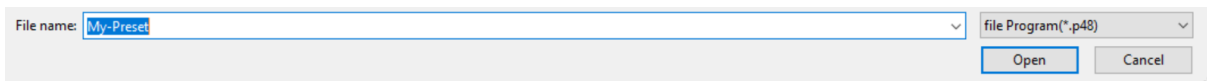

## SAVE

Click the **[SAVE]** button to save the currently loaded preset to the computer.

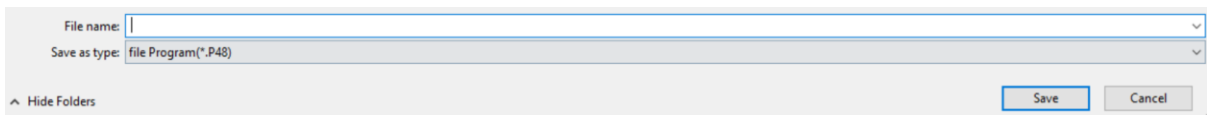

## STORE

To save a preset to one of the 24 the internal memory slots of the SP48 click the **[STORE]** button. The in the next screen select the position from the drop-down menu and enter the desired preset name. Click **[Store]** to confirm saving the preset to the internal SP48.

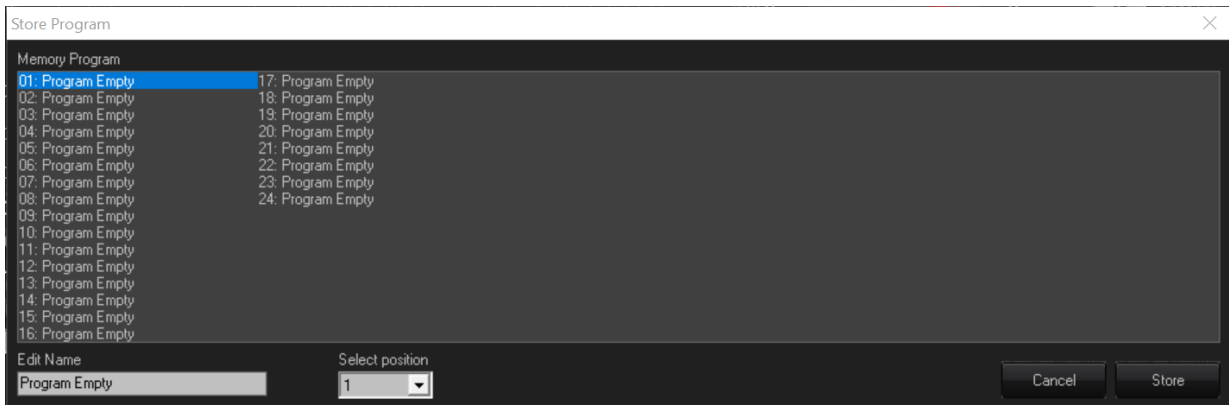

## RECALL

To load a preset from the SP48s internal memory, click the **[RECALL]** button. Next select the desired preset to load from the list.

**WARNING Any unsaved changes will be lost when loading a preset!**



## COPY IN

It is possible to copy the settings from one input channel to another. Click the **[COPY IN]** button to bring up the copy input window. Select the input channel source and destination, click **[Confirm]** to copy the parameters from source to destination.

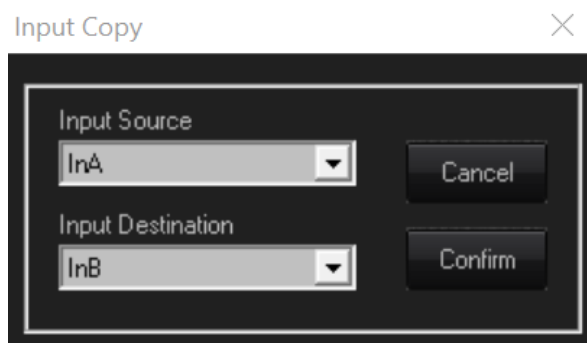

## COPY OUT

Similar to the **[COPY IN]** button, you can also use the **[COPY OUT]** button to copy one output to another.



## DEFAULT

To reset the current preset to factory defaults, press the **[DEFAULT]** button. A confirmation dialogue will appear, press **[Yes]** to confirm.

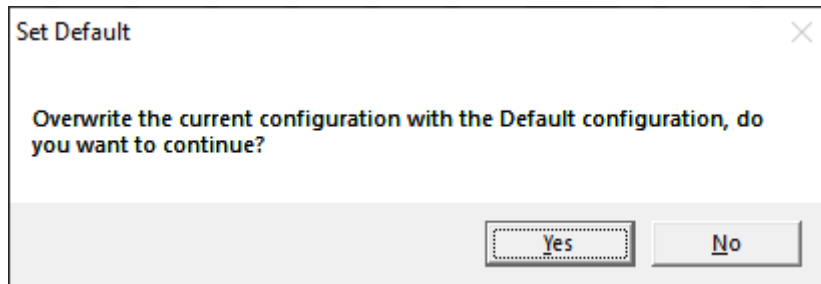

## USER

The **[USER]** menu allows changing of the inbuilt security password of the SP48. First enter the current password, then on the next screen enter the new password twice and click confirm.

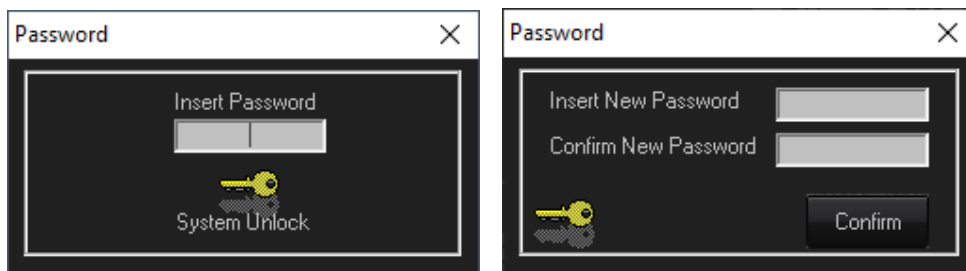

## LOCK

Press the **[LOCK]** button to lock editing of parameters. When enabled the **[LOCK]** button will display LOCKED in red, no parameters can be edited, and the unit will remain locked even when disconnected. Click the **[LOCK]** button again to return to normal behaviour.



## PASSWORD

Similar to the **[LOCK]** button pressing **[PASSWORD]** will disable any parameter editing on the SP48. The different is that a password input is required to un-lock the unit. The password is set with the **[USER]** button.

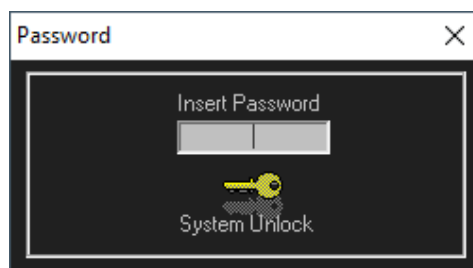

## ABOUT

Shows the current software and firmware version.

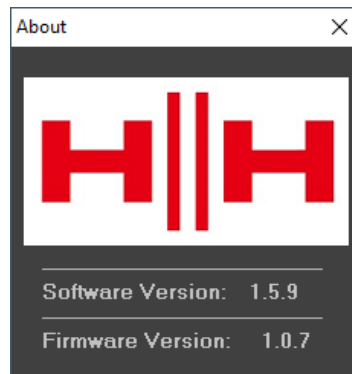

# TECHNICAL SPECIFICATIONS

Type	Loudspeaker Management System
Audio	
Inputs	Four Electronically Balanced XLR Inputs
Outputs	Eight Electronically Balanced XLR Outputs
Minimum Load	150 Ohms
THD%N	0.001% at 1kHz 0dBu
S/N	>106dBA
Frequency Response	20Hz-20kHz; -0.5dB at 20Hz and 20kHz
AD/DA Converters	24bit, 48kHz
General	
Presets	24 user presets
Other	Audio Ground Lift switch, USB/RS485 ground lift switch
Remote	USB remote control and RS485 in/out RJ45 connectors for control and monitoring of up to 32 units
DSP	
DSP Engine	DSP, 24bit (data)
DSP Resolution	24bit (data) x 24 bit (coeff.), 54 bit accregisters. 96 bit precision on intermediate processing data
Parametric Equalisation	30 filters per input, 7 filters per output
Filter Type	Bell, Hi/Lo Shelving, HP/LP, BP, Notch, All Pass
Filter Gain	From -15dBu up to +15dBu by 0.5dBu resolution steps
Centre Frequency	from 20Hz up to 20kHz with 1Hz resolution steps
Filter Q/BW	Bell Q: 0.4~128, Shelving/HP/LP Q: 0.1~5.1, BP/Notch/All Pass Q:4~104
Input Gain	From -18dB to +12dB by 0.1dBu resolution steps;
Output Gain	From -18dB to +12dB by 0.1dBu resolution steps;
Crossover Section HPF/LPF	Butterworth 6/12/18/24/36/48 dB per octave. Bessel 12/24 dB per octave. Linkwitz-Riley 12/24/36/48 dB per octave
Input Noise Gate	Threshold from -80dBu up to -50dBu. Attack time from 1ms up to 1000ms;Release time from 10ms up to 1000ms
Input RMS Compressor	Threshold from -14dBu up to +16dBu and Bypass. Ratio 2:1~32:1; Knee: 0% ~ 100%. Attack time from 5ms up to 200ms;Release time from 0.1 sec up to 3 sec
Output RMS Compressor	Threshold from -14dBu up to +16dBu and Bypass. Ratio 2:1~100:1; Knee: 0% ~ 100%. Make-Up from -12dB to +12dB. Attack time from 5ms up to 200ms;Release time from 0.1 sec up to 3 sec
Output Peak Limiter	Threshold from -14dBu up to +16dBu and Bypass. Attack time from 1ms up to 900ms;Release time from 0.1 sec up to 5 sec.
Delay	420ms per input channel, 10.4us increment/decrement steps. 129ms 10.4us increment/decrement steps per output channel
Residual Noise	<-90dBu
Power Requirements	
AC Power	Universal voltage 100V-240V~ 50/60Hz, three pin IEC socket
AC Power Consumption	<30W
Sizes	
Unit dimensions (HWD)	44 x 483 x 229mm, 1.7" x 19" x 9"
Unit weight	3.5Kg, 7.7 lbs
Carton dimensions (HWD)	9 x 53 x 30CM, 3.5" x 20.9" x 11.8" , 0.014 M3
Packed weight	4.5Kg, 9.9 lbs
EAN	5060109458305

## DIMENSIONAL DATA (in mm)

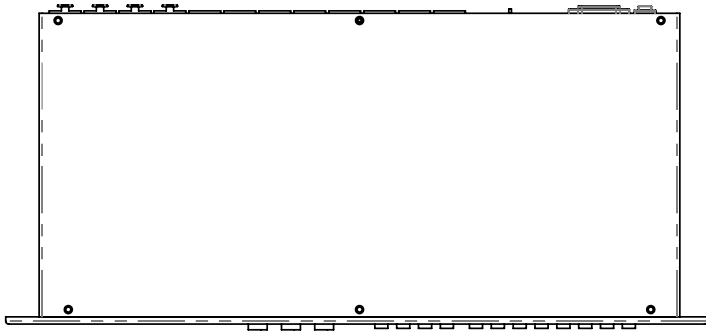

TOP

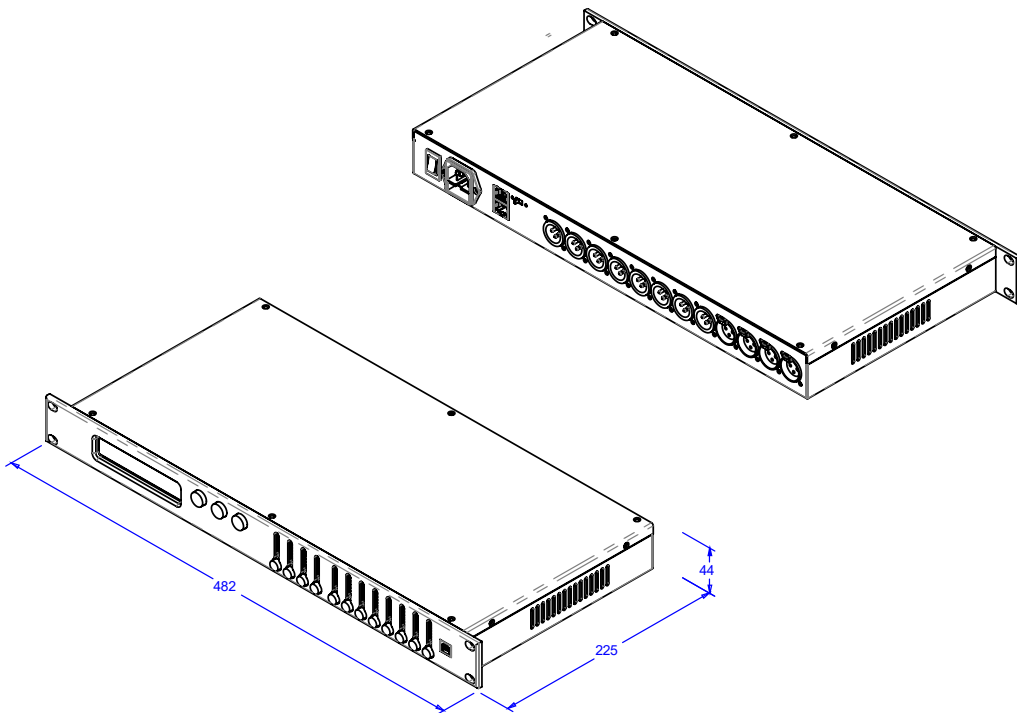
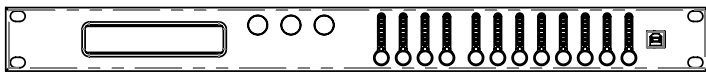

# SAFETY INFORMATION

In order to take full advantage of your new product and enjoy long and trouble-free performance, please read this owner's manual carefully, and keep it in a safe place for future reference.

- 1) **Unpacking:** On unpacking your product please check carefully for any signs of damage that may have occurred whilst in transit from the HH factory to your dealer. In the unlikely event that there has been damage, please re-pack your unit in its original carton and consult your dealer. We strongly advise you to keep your original transit carton, since in the unlikely event that your unit should develop a fault, you will be able to return it to your dealer for rectification securely packed.
- 2) **Amplifier Connection:** In order to avoid damage, Generally it is advisable to establish and follow a pattern for turning on and off your system. With all system parts connected, turn on source equipment, mixers, effects processors etc, BEFORE turning on your amplifier. Many products have large transient surges at turn on and off which can cause damage to your speakers. By turning on your amplifier LAST and making sure its level control is set to a minimum, any transients from other equipment should not reach your loud speakers. Wait till all system parts have stabilised, usually a couple of seconds. Similarly when turning off your system always turn down the level controls on your amplifier and then turn off its power before turning off other equipment.
- 3) **Cables:** Never use shielded or microphone cable for any speaker connections as this will not be substantial enough to handle the amplifier load and could cause damage to your complete system. Use good quality shielded cables everywhere else.
- 4) **Servicing:** The user should not attempt to service these products. Refer all servicing to qualified service personnel.
- 5) Heed all warnings.
- 6) Follow all instructions.
- 7) Do not use this apparatus near water.
- 8) Clean only with a dry cloth.
- 9) Do not block any of the ventilation openings. Install in accordance with manufacturer's instructions.
- 10) Do not install near any heat sources such as radiators, heat registers, stoves or other apparatus (including amplifiers) that produce heat.
- 11) An apparatus with Class I construction shall be connected to a mains socket outlet with a protective connection. Do not defeat the safety purpose of the polarized or grounding-type plug. A polarized plug has two blades with one wider than the other. A grounding type plug has two blades and a third grounding prong. The wide blade or third prong is provided for your safety. If the provided plug does not fit into your outlet, consult an electrician for replacement of the obsolete outlet.
- 12) Protect the power cord from being walked on or pinched, particularly at plugs, convenience receptacles, and the point they exit from the apparatus.
- 13) Only use attachments/accessories provided by the manufacturer.
- 14) Use only with a cart, stand, tripod, bracket, or table specified by the manufacturer, or sold with the apparatus. When a cart is used, use caution when moving the cart/apparatus combination to avoid injury from tip-over.
- 15) The mains plug or appliance coupler is used as the disconnect device and shall remain readily operable. The user should allow easy access to any mains plug, mains coupler and mains switch used in conjunction with this unit thus making it readily operable. Unplug this apparatus during lightning storms or when unused for long periods of time.
- 16) Refer all servicing to qualified service personnel. Servicing is required when the apparatus has been damaged in any way, such as when power-supply cord or plug is damaged, liquid has been spilled or objects have fallen into the apparatus, the apparatus has been exposed to rain or moisture, does not operate normally, or has been dropped.
- 17) Never break off the ground pin. Connect only to a power supply of the type marked on the unit adjacent to the power supply cord.
- 18) If this product is to be mounted in an equipment rack, rear support should be provided.
- 19) Note for UK only: If the colours of the wires in the mains lead of this unit do not correspond with the terminals in your plug, proceed as follows:
  - o The wire that is coloured green and yellow must be connected to the terminal that is marked by the letter E, the earth symbol, coloured green or coloured green and yellow.
  - o The wire that is coloured blue must be connected to the terminal that is marked with the letter N or the colour black.
  - o The wire that is coloured brown must be connected to the terminal that is marked with the letter L or the colour red.
- 20) This electrical apparatus should not be exposed to dripping or splashing and care should be taken not to place objects containing liquids, such as vases, upon the apparatus.
- 21) Exposure to extremely high noise levels may cause a permanent hearing loss. Individuals vary considerably in susceptibility to noise-induced hearing loss, but nearly everyone will lose some hearing if exposed to sufficiently intense noise for a sufficient time. The U.S. Government's Occupational Safety and Health Administration (OSHA) has specified the following permissible noise level exposures: According to OSHA, any exposure in excess of the above permissible limits could result in some hearing loss. Earplugs or protectors to the ear canals or over the ears must be worn when operating this amplification system in order to prevent a permanent hearing loss, if exposure is in excess of the limits as set forth above. To ensure against potentially dangerous exposure to high sound pressure levels, it is recommended that all persons exposed to equipment capable of producing high sound pressure levels such as this amplification system be protected by hearing protectors while this unit is in operation.
- 22) If your appliance features a tilting mechanism or a kickback style cabinet, please use this design feature with caution. Due to the ease with which the amplifier can be moved between straight and tilted back positions, only use the amplifier on a level, stable surface. DO NOT operate the amplifier on a desk, table, shelf or otherwise unsuitable non-stable platform.
- 23) Symbols & nomenclature used on the product and in the product manuals, intended to alert the operator to areas where extra caution may be necessary, are as follows:

Duration Per Day in Hours	Sound Level dBA, slow response
8	90
6	92
4	95
3	97
2	100
1 1/2	102
1	105
1/2	110
1/4 ou inférieur	115

 <b>CAUTION:</b>	<p>Intended to alert the user to the presence of uninsulated 'Dangerous Voltage' within the products enclosure that may be sufficient to constitute a risk of electrical shock to persons.</p> <p>Ce symbole est utilise pur indiquer a l'utilisateur de ce produit de tension non-isolee dangereuse pouvant etre d'intensite suffisante pour constituer un risque de choc electrique.</p> <p>Este simbolo tiene el proposito de alertar al usuario de la presencia de '(voltaje) peligroso' que no tiene aislamiento dentro de la caja del producto que puede tener una magnitud suficiente como para constituir riesgo de corrientazo.</p> <p>Dieses Symbol soll den Anwender vor unisolierten gefahrlichen Spannungen innerhalb des Gehauses warnen, die von Ausreichender Starke sind, um einen elektrischen Schlag verursachen zu konnen.</p>
 <b>WARNING:</b>	<p>Intended to alert the user of the presence of important operating and maintenance (Servicing) instructions in the literature accompanying the product.</p> <p>Dieses Symbol soll den Anwender vor unisolierten gefahrlichen Spannungen innerhalb des Gehauses warnen, die von Ausreichender Starke sind, um einen elektrischen Schlag verursachen zu konnen.</p> <p>Este simbolo tiene el proposito de la alertar al usuario de la presencis de instrucccones importantes sobre la operacion y mantenimiento en la literatura que viene conel producto.</p> <p>Dieses Symbol soll den Benutzer auf wichtige Instruktionen in der Bedienungsanleitung aufmerksam machen, die Handhabung und Wartung des Produkts betreffen.</p>
<b>CAUTION:</b>  <b>ATTENTION:</b>  <b>PRECAUCION:</b>  <b>VORSICHT:</b>	<p>Risk of electrical shock - DO NOT OPEN. To reduce the risk of electrical shock, do not remove the cover. No user serviceable parts inside. Refer servicing to qualified personnel.</p> <p>Risques de choc electrique - NE PAS OUVIRIR. Afin de reduire le risque de choc electrique, ne pas enlever le couvercle. Il ne se trouve a l'interieur aucune piece pouvant etre reparee par l'utilisateur. Confier l'entretien a un personnel qualifie.</p> <p>Riesgo de corrientazo - no abra. Para disminuir el risego de corrientazo, no abra la cubierta. No hay piezas adentro que el pueda reparar. Deje todo mantenimiento a los tecnicos calificadod.</p> <p>Risiko - Elektrischer Schlag! Nicht offen! Um das Risiko eines elektrischen Schlages zu vermeiden, nicht die Abdeckung entfernen. Es befinden sich keine Teile darin, die vow Anwender repariert werden Konnten. Reparaturen nur von qualifiziertem Fachpersonal durchfuhren lassen.</p>
<b>WARNING:</b>  <b>ADVERTISSEMENT:</b>  <b>ADVERTENCIA:</b>  <b>ACHTUNG:</b>	<p>To prevent electrical shock or fire hazard, do not expose this appliance to rain or moisture. Before using this appliance please read the operating instructions for further warnings.</p> <p>Afin de prevenir les risques de decharge electrique ou de feu, n'exposez pas cet appareil a la pluie ou a l'humidite. Avant d'utiliser cet appareil, lisez les advertissements supplementaires situes dans le guide.</p> <p>Para evitar corrientazos o peligro de incendio, no deja expuesto a la lluvia o humedad este aparato Antes de usar este aparato, lea mas advertcias en la guia de operacion.</p> <p>Um einen elektrischen Schalg oder Feuergefahr zu vermeiden, sollte dieses Gerat nicht dem Regen oder Feuchtigkeit ausgesetzt werden. Vor Inbetriebnahme unbedingt die Bedienungsanleitung lesen.</p>
	<p>This device complies with Part 15 of the FCC rules Operation is subject to the following two conditions:</p> <ol style="list-style-type: none"> <li>1) This device may not cause harmful interference</li> <li>2) This device must accept any interference received, that may cause undesired operation.</li> </ol> <p>Warning: Changes or modification to the equipment not approved by HH can void the user's authority to use the equipment.</p> <p>Note: This equipment has been tested and found to comply with the limits for Class B digital device, pursuant to Part 15 of the FCC Rules. These limits are designed to provide reasonable protection against harmful interference in a residential installation. This equipment generates, uses and can radiate radio frequency energy and if not installed and used in accordance with the instructions, may cause harmful interference to radio communications. However, there is no guarantee that interference will not occur in a particular installation. If this equipment does cause harmful interference to radio or television reception, which can be determined by turning the equipment off and on, the user is encouraged to try and correct the interference by one or more of the following measures. Reorient or relocate the receiving antenna. Increase the separation between the equipment and receiver. Connect the equipment into an outlet on a circuit different from that to which the receiver is connected. Consult the dealer or an experienced radio/TV technician for help.</p>
	<p>This product conforms to the requirements of the following European Regulations, Directives &amp; Rules: CE Mark (93/68/EEC), Low Voltage (2014/35/EU), EMC (2014/30/EU), RoHS (2011/65/EU), ErP (2009/125/EU)</p> <p><b>SIMPLIFIED EU DECLARATION OF CONFORMITY</b></p> <p>Hereby, HH Electronics Ltd. declares that the radio equipment is in compliance with Directives 2014/53/EU, 2011/65/EU, 2009/125/EU. Full text of the EU declaration of conformity is available at the following internet address:</p> <p><a href="http://support.hhelectronics.com/approvals">http://support.hhelectronics.com/approvals</a></p>
	<p>The object of the declaration described above is in conformity with the relevant statutory requirement Electrical Equipment (Safety) Regulations 2016, Electromagnetic Compatibility Regulations 2016, The Restriction of the use of Certain Hazardous Substances in Electrical and Electronic Equipment Regulations 2012, The Ecodesign for Energy-Related Products and Energy Information, (Amendment) (EU Exit) Regulations 2012</p>
	<p>In order to reduce environmental damage, at the end of its useful life, this product must not be disposed of along with normal household waste to landfill sites. It must be taken to an approved recycling centre according to the recommendations of the WEEE (Waste Electrical and Electronic Equipment) directive applicable in your country.</p>





HH ELECTRONICS LTD.  
STEELPARK ROAD, COOMBSWOOD BUSINESS PARK WEST, HALESOWEN, B62 8HD.  
HH ELECTRONICS IS PART OF HEADSTOCK GROUP

[WWW.HHELECTRONICS.COM](http://WWW.HHELECTRONICS.COM)

**IN THE INTEREST OF CONTINUED DEVELOPMENT, HH RESERVES THE RIGHT TO AMEND PRODUCT SPECIFICATION WITHOUT PRIOR NOTICE**